

Plain Nut Discharge Head

FEATURES

- Plain Nut Discharge Head can be Actuated by Electric or Pneumatic Control Head or by Back Pressure from the Manifold
- Plain Nut Discharge Head is used with Single and Multiple Nitrogen Driver Systems
- UL Listed, File Number 4674
- FM Approved
- RoHS Compliant

DESCRIPTION

At installation, each Kidde Fire Systems ADS™ Fire Suppression System (ADS System) nitrogen driver cylinder and valve assembly must be equipped with a discharge head to actuate the nitrogen driver cylinder valve. The discharge head is assembled to the top of the nitrogen driver cylinder valve and contains a spring-loaded piston which, when actuated by nitrogen pressure, is designed to depress the main check in the valve and transfer the contents of the nitrogen tank into the agent cylinder. The transfer outlet is designed to mate with the swivel adapter on the 1-in. flexible transfer hose (P/N 06-118207-00X). The discharge head also contains an integral stop check which, in the event that a cylinder is removed from the ADS system assembly, automatically prevents the loss of nitrogen during the system transfer. The plain nut discharge head allows the nitrogen driver to be actuated by the control head (electric or pneumatic) or by back pressure discharge in the manifold. The plain nut discharge head is convenient for applications using multiple drivers for one agent cylinder.

Note: For additional detail regarding ADS system delivery manifolding, refer to the coordinating DIOM.

MAINTENANCE

MONTHLY:

Inspect nitrogen driver discharge head for cracks, corrosion, grime, etc. Ensure that the discharge head is tightly secured to the nitrogen cylinder valve and connected to the agent cylinder with the 1-in. nitrogen transfer hose. If any defects are found during the monthly inspection, immediately contact an authorized Kidde Fire Systems Distributor to service the systems.

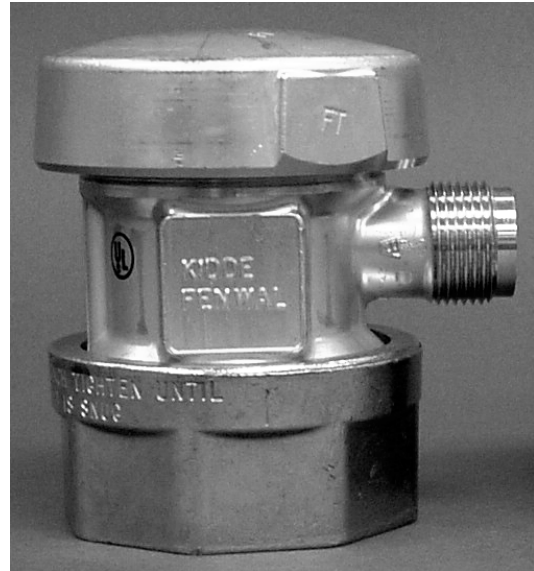

INSTALLATION

1. Wipe off cylinder valve sealing surface.
2. Verify that the O-rings are installed in the mating surface grooves at the bottom of the swivel nut cavity. O-rings must be free of dirt or other contaminants. The O-rings have been lightly greased at the factory and should not require further greasing.
3. Make sure the pilot orifice located between the inner and outer O-ring is unobstructed.
4. Make sure the discharge port is clean and unobstructed.
5. Install the discharge head on the cylinder valve. Tighten securely.



The agent storage cylinder must be permanently connected to the system piping. Never attach the discharge head to the cylinder valves until the cylinders are secured in brackets or racking and the hose is attached to the agent cylinder. Under no circumstances should the discharge head remain attached to the cylinder valve after removal from service or during shipment, handling, storage or filling. In the event of an inadvertent discharge, failure to follow these instructions could result in death, serious bodily injury and/or property damage.

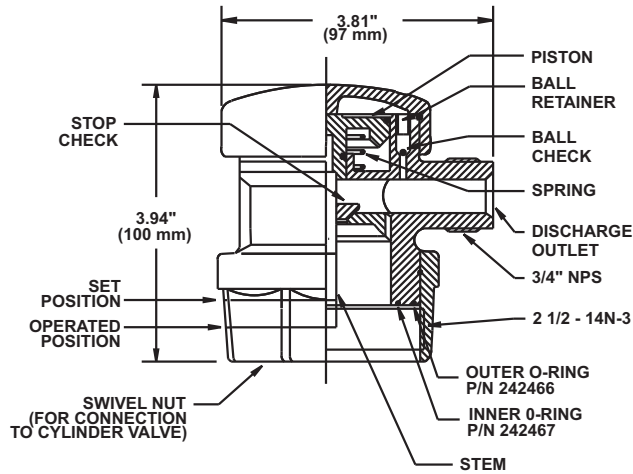

Discharge Head, Plain Nut:
For use with Single and Multiple Nitrogen Driver Systems

SPECIFICATIONS

MATERIALS

- **Body:** Brass
- **O-rings:** Rubber
- **Spring:** Stainless Steel
- **Stop Check:** Brass
- **Weight:** 4.0 lb. (1.8 kg)

ORDERING INFORMATION

Part Number	Description
WK-872450-000	Plain Nut Discharge Head

COMPATIBILITY

Series	DIOM P/N	Approvals
Kidde Fire Systems ADS™ for use with Fluoroketone Fire Suppression Agents	06-237256-001	UL, ULC, FM
Kidde Fire Systems ADS™ Marine for use with Fluoroketone Fire Suppression Agents	06-237257-001	UL, ULC, USCG
Kidde Fire Systems ADS™ with HFC-227ea Agent	06-236068-001	UL, ULC, FM
Kidde Fire Systems ADS™ Marine with HFC-227ea Agent	06-236595-001	UL, ULC, USCG

EXPORT INFORMATION (USA)

Jurisdiction: EAR
Classification: EAR99

This document contains technical data subject to the EAR.

All trademarks are the property of their respective owners.

This literature is provided for informational purposes only. KIDDE-FENWAL, INC. believes this data to be accurate, but it is published and presented without any guarantee or warranty whatsoever. KIDDE-FENWAL, INC. assumes no responsibility for the product's suitability for a particular application. The fire suppression system design, installation, maintenance, service and troubleshooting must be performed by trained, authorized Kidde Fire Systems distributors for the product to work correctly. If you need more information on this product, or if you have a particular problem or question, contact: KIDDE-FENWAL, INC., Ashland, MA 01721 USA, Telephone: (508) 881-2000.